

Viking
Enviroclad

keeping
water on
the outside

Roofspec
Viking
Taking care of detail

www.vikingroofspec.co.nz



Viking Enviroclad: **world-class proven performer**

Viking Enviroclad offers absolute watertight integrity for low-slope roofs. It is a TPO (thermoplastic polyolefin) waterproofing membrane, rendering all the necessary attributes of a world-class system, from waterproofing, aesthetic and environmental perspectives.

The benefit for building owners is Viking Enviroclad's proven performance both internationally and locally. Launched in the USA in 1990 and now the world's largest selling TPO; Viking Enviroclad was introduced to New Zealand in 2007 and has since been installed on tens of thousands of homes and commercial buildings across the country and the Pacific Islands.

Viking Enviroclad is manufactured by the world's largest and most technologically advanced manufacturer of single-ply waterproofing membranes, Carlisle Construction Materials.

Viking Enviroclad is a mesh-reinforced, thermoplastic, heat-weldable waterproofing membrane that can be installed on most new substrate surfaces, as well as over many existing membranes.

Viking Enviroclad possesses strong UV and puncture resistance properties and the reinforcing mesh provides latitudinal strength, meaning Enviroclad is extremely forgiving of structural movement.

Viking Enviroclad is suitable for low-slope and pitched roofs, gutters and parapets, pond liners, balconies, under floating decks and roof gardens of commercial and residential buildings.

Superior quality: delivering greater benefits

Energy Saving

Viking Enviroclad is highly-reflective, with the white option reflecting over 90% of the solar radiation that hits it. This will directly reduce amount of the energy required to cool a building's interior.

Viking Enviroclad can be used as the waterproofing membrane for Viking's WarmRoof and WarmSpan systems, which render even greater energy savings through their insulation components.

In the USA, Enviroclad is US ENERGY STAR® rated and Cool Roof Rating Council certified. In New Zealand, Viking Enviroclad is CodeMark certified and BRANZ appraised.

The reduction in energy consumption contributes points to a building's Green Star rating.

Environmental Benefits

Viking Enviroclad is 100% recyclable, due to the absence of chlorinators and plasticisers in the composition of the product.

During the manufacturing process, off-cuts are recycled. Enviroclad is also supplied cut-to-length if requested, meaning minimal waste.

Viking Enviroclad is potability certified, meaning drinking water can be safely collected off an Enviroclad roof, if a filtration system is installed.

The fact that Enviroclad seams are heat-welded negates the need for oil-based splicing systems like tapes and primers. It can also be installed using mechanical fastenings, negating the use of adhesives if desired.

Water Tight Integrity

Viking Enviroclad's heat-weldability creates stronger and flatter seams (vulcanised at 400°C). This technology also renders quicker installation time while ensuring watertight integrity.

System features

- 100% recyclable
- High UV resistance
- High reflectivity
- Water potability certified
- Formulated to suit a wide range of climatic conditions
- Compatible with Viking WarmRoof and Viking WarmSpan systems
- Enviroclad-specific licensing school in Auckland
- Installed only by Licensed Installers
- 20-year product warranty
- CodeMark certified
- BRANZ appraised
- Heat-weldable seams
- Proprietary weldable accessories
- Overlay Option
- Cut to length service available
- Mesh scrim inherent in membrane sheet for latitudinal strength
- Wide rolls – (up to 4.88m) = less seams
- Long rolls – (30.4m) = less seams

Product Assurance

Certain areas of New Zealand can be subjected to some of the toughest climatic conditions in the civilised world. This calls for construction materials to stand the test of time. At Viking Roofspec we offer quality assurance from CodeMark certifications and BRANZ appraisals, two of the highest possible forms of product assurance. Viking Roofspec has invested more funds into the appraisal and certification of our waterproofing materials than any of our competitors.



Comprehensive Quality Assurance

Viking Enviroclad is backed by a 20 year warranty.*

Projects that represent 'absolute risk minimisation' in design, may also be eligible for Viking's comprehensive Full System Warranty* that covers both the materials and the approved applicator's installation in one document for the building owner.

*Conditions Apply – for more information on Viking's Full System Warranty, visit: www.vikingroofspec.co.nz



Viking
Approved
Applicator

Viking Enviroclad offers the largest colour range in New Zealand's Sheet Membrane market

Note – The colours shown in this brochure are a digital representation of the actual colours. Before making a final selection, Viking Roofspec recommends viewing actual material samples and/or existing roof installations.

Standard colour range

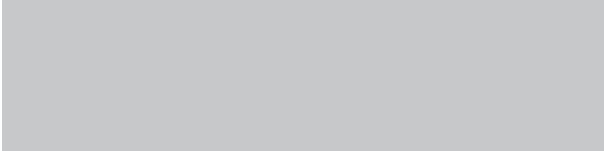

Dove Grey (CodeMark certified)

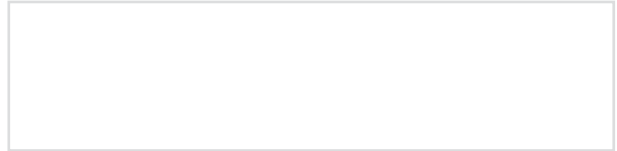

White (CodeMark certified)

Exciting earth tone colour range



Medium Bronze

Medium Bronze

Medium Bronze complements a building where natural products have been used as cladding. It also allows the building to blend in with natural surroundings. This tone is well suited to all climate zones, however performs extremely well in cooler regions as it is more heat-absorbent.



Rock Brown

Rock Brown

The lightest tone of the five new colours, Rock Brown offers property owners warmth and versatility; especially when trying to blend the property into a natural backdrop. This colour also complements warm-toned cladding options, including brick, stone and timber.



Slate Grey

Slate Grey

A Slate Grey membrane combines well with natural claddings such as weatherboards, cedar, stone, brick or copper. This colour tone reduces the glare due to its darker tint. Like the other colours, it's well suited to any region; especially the cooler zones.



Patina Green

Patina Green

In New Zealand's predominantly green landscape, our Patina Green Enviroclad is an ideal choice if a property is surrounded by forestry or bush. It allows the building to match the landscape and tastefully blend into rural environments.



Ironsand

Ironsand

Ironsand is a smoky deep brown/charcoal shade, inspired by the rugged landscape of the West Coast. This popular exterior colour choice blends beautifully with natural surroundings.

To order a colour range sample box please email info@vikingroofspec.co.nz or phone 0800 729 799



Enviroclad colours: striking earth tone colour range

Viking Roofspec offers Enviroclad TPO in seven colour tones, providing architects and building owners versatility for the aesthetics of their designs and buildings respectively.

Not all flat roofs are unseen. These colours can add extra flare to a surface that would normally have been Dove Grey or White.

Advantages of specifying a coloured membrane

- The opportunity to make a visual statement
- Provides flexibility and versatility to colour schemes
- Earthy tones blend more tastefully in rural, bush and coastal areas
- Assists with compliance in those council zones where cladding shade L.R.V.s (light reflective values) can't exceed 40 LRV
- Provides minimal glare from the roof, a 'neighbour-friendly' option if their home/building looks down on to it

This colour range allows you to complement other construction materials such as timber, stone or copper; all with tones found in natural surroundings.

Our coloured Enviroclad range offers the same watertight integrity as standard Dove Grey or White Enviroclad.

CASE STUDY: Viking Enviroclad Mansard Brown

Why be normal

Viking Enviroclad has created a visual statement for a home, while allowing it to blend in amongst its natural backdrop

THE CHALLENGE

A beautiful cliff-edge home overlooking New Zealand's iconic Piha beach needed a new roof - the old one had fulfilled the Building Code's minimum 15 year durability requirement, and was beginning to perish in places and needed to be replaced.

The homeowners were looking for a solution that would waterproof their home without causing too much disturbance, or change the look drastically.

THE SOLUTION

The dark-brown shade of the Mansard Brown Enviroclad meant the homeowners could complement the dark timber cladding, while allowing the roof to blend in with the surroundings.

This particular roof has a slope of 22 degrees; a slope that would normally be clad with traditional roofing materials such as long run steel or tiles. Due to the versatility and flexibility of Enviroclad TPO membrane as well as its durability in this coastal situation (non corrosive in a salt spray zone); it was the perfect solution.

THE RESULT

Choosing a coloured roofing membrane has allowed the homeowners to veer away from traditional roofing colour schemes, creating a visual statement for their home while blending in amongst its natural backdrop— all with the knowledge that their non-corrosive membrane roof is perfect for coastal conditions and backed with a 20 year product warranty.



CASE STUDY: Ahuriri Valley Lodge



Stunning protection from an extreme environment

THE CHALLENGE

Sitting amongst the rolling topography of the glacial moraine in the remote Ahuriri valley, three hours inland from Queenstown and overlooking the glimmering Ahuriri River, sits the Lindis Lodge; a beautiful new five-bedroom luxury chalet.

Designed by Wellington based architects, Architecture Workshop Ltd with their consultants; Dunning Thornton Consultants, Ecubed, Holmes Fire and constructed by Brosnan Construction, the Lindis Lodge was designed to complement the landscape in an environmentally friendly way, as well as nestle in to the grandeur of the glacial valley whilst affording maximum luxury and ambience.

The innovative structural hardwood gridshell folds over the Great Hall (the main interior space) and anchors the building into the ground, creating an organic aesthetic that required sophisticated parametric analysis and innovative construction detailing to realise.

As it is located in the Southern Alps, the Lindis Lodge needed a complete waterproofing solution to comply with the building code and withstand the extreme environment. There was also the additional challenge of finding a system that allowed for a hardwood rainscreen to be installed on top of the membrane – with limited penetrations.



THE SOLUTION

“Enviroclad provides a good tough TPO waterproofing system which accommodated a heat welded batten connection for us to detail the hardwood rainscreen roof with the engineers. The heat-welded laps and flashing edges are a huge positive, as well as the weldable boot-flashing around the lintel protrusions. The builders and roofing system dealt well with the demanding shape of the large roof”

– Christopher Kelly, founding principal of Architecture Workshop

THE RESULT

The builders and Viking Approved Applicators have done an exceptional job constructing and waterproofing such a beautiful, structurally innovative building, capable to handle the harshest of NZ conditions.

Viking Enviroclad is a CodeMark and BRANZ appraised product that comes with a 20 year product warranty, backed by Tiri Group.

Alternative Viking Enviroclad solutions to meet your needs

Viking Enviroclad APEEL

Viking Enviroclad's factory applied protective film called APEEL, temporarily guards the surface of the membrane from scuffs and dirt accumulation during installation and subsequent construction process. On completion the protective front layer is peeled off by the roofing applicator to leave a pristine shiny roof surface.

Durable and easy

Enviroclad APEEL protective film will stay in place until it is ready to be removed. Strong adhesion levels allow the film to stay in place for up to three months, resisting the effects of heat, UV exposure, rain and wind. Once the film is removed, no residue remains on the membrane, providing the building owner with a clean, reflective roof that will continue to resist dirt pick-up long after installation.

APEEL is ideal for re-roofing and new construction projects.

Time and Labour Savings

It is understandably common practice for building owners to request that their new membrane roof be cleaned before they pay for it. With Enviroclad APEEL, there is no need for an applicator to go through the labourious; sometimes toxic; and imperfect cleaning or power-washing process after installation. They simply remove the film, and the roof is ready for final inspection.

Enviroclad APEEL is available in 1.52mm thickness, in 3.05m wide and in grey.



Viking Enviroclad F.B.S. (fleece-backed system)

Viking Enviroclad FBS is a waterproofing membrane where a 'fluffy' polyester layer has been factory-laminated to the underside of the waterproofing membrane.

Enviroclad FBS is recognised as one of the best re-roofing solutions for overlaying on top of a wide-range of existing roof surfaces such as old bitumen, malthoid or rough substrates such as concrete and tongue and groove sarking.

Enviroclad FBS (fleece-backed system) is a membrane re-roofing solution consisting of 1.4mm of polyester fleece-backing factory-laminated to 1.14mm of TPO (thermoplastic polyolefin).

Silk Purse

The fleece-on the membrane's underside bonds with the substrate, partially forgiving the rough surface into which it beds itself, rendering a surprisingly smooth, aesthetic membrane surface finish. An unsightly, rough substrate would otherwise 'telegraph' more of its imperfections through the surface of any non-fleece backed single-ply membrane.

Reduction in Waste

In many instances, there is no need to dump the old roof surface, as FBS can be applied over a wide-range of existing roof surfaces* leading to a reduction in waste, as the old roof surface doesn't fill-up our local landfills.

Reduction in Cost and 'Churn'

Overlaying an existing membrane means there are no costs involved in stripping the current surface; redesigning, reconditioning or reconstructing the existing roof. This also avoids exposing the interior to adverse weather conditions – or relocating people while the overlay takes place – an expensive process also known as 'churn'.

Puncture Resistance

The fleece-backing of the FBS membrane adds additional puncture resistance to the already high puncture resistance of the Viking Enviroclad membrane, possessing a 33% greater puncture resistance than most membranes.

*Only if an invasive investigation has confirmed the integrity of the substrate. Please note: decayed substrates require complete replacement.



RhinoBond machine

How RhinoBond works

4. RhinoBond Induction machine
3. TPO coated plate
2. Enviroclad TPO membrane
1. Roofing substrate

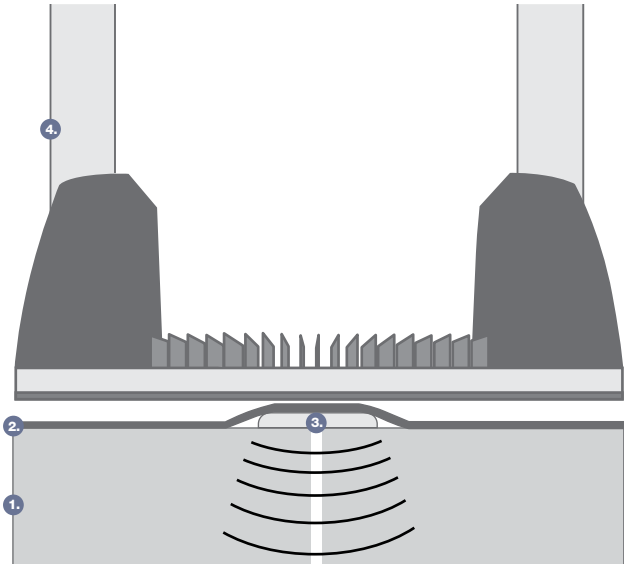

RhinoBond induction welded mechanical fastening

In line with the construction industry's continuous evolution, there are a growing number of substrate options onto which membranes can be installed.

A common question is whether Enviroclad can be laid over substrates other than plywood, concrete or rigid insulation. The main issue is adhesion. With the RhinoBond method of fixing, you can be certain that the strongest possible adhesion will be achieved.

What is RhinoBond?

RhinoBond is induction fastening technology, an alternative method of mechanically-fastening Enviroclad membrane to a wide range of substrates. The difference from other types of mechanical fastening is that it doesn't involve penetrating the membrane.

How does it work?

TPO-coated metal plates are fastened to the substrate in a grid pattern. Enviroclad membrane is laid over the plates and appropriately positioned on the roof as per a normal installation. The RhinoBond induction welding tool is placed above each of the RhinoBond plates (which are underneath the membrane surface).

The induction tool emits an electro-magnetic charge through the membrane, which activates the TPO coating on the surface of the plate below, resulting in a weld between the plate surface and the underside of the membrane (in less than five seconds). Weighted magnets are then temporarily placed over the plates to dissipate heat and ensure intimate contact between the bottom surface of the membrane and the integral hot-melt TPO coating on the plate's surface. This results in a superb weld.

Benefits of RhinoBond

- No adhesive required
- No membrane penetration
- Improved productivity – due to less fasteners and plates required than traditional mechanical fastening
- Maximum wind uplift resistance
- No narrow perimeter sheets required
- Negates membrane flutter
- Symmetrical wind load distribution
- Negates membrane fatigue at seams
- No weather or temperature dependence

CASE STUDY: Viking Enviroclad APEEL



before



after

“I’d like an ‘APEEL – Rhino – Warm Roof’ Combo please!”

THE CHALLENGE

A large nursing home in central Auckland had thousands of square metres of metal tray roofing with minimal pitch that was in a state of disrepair and leaking. These roofs needed to be sorted, but firstly, there were a couple of challenges:

Budget: The trust board didn’t have income for the metal roof to be removed nor for carpenters to build a support structure to re-pitch a new one at the three degrees required for metal roofs.

Practicality: Removal of a roof requires the relocation of people, an inconvenient and expensive process, especially when elderly patients are involved.

Noise: Projects like this can be noisy, the last thing people in the twilight of their lives need to be subjected to.

Safety: The buildings have a number of extractor fans, so the fumes from an adhesive system could find their way into a building and affect the patients and staff.

Damage: A number of other trades would be following the roofing project, so there was a danger the membrane surface could be damaged.

THE SOLUTION

A warm roof overlay was proposed to be installed on top of the existing roof. The existing metal tray roof would remain in place so the building would remain covered and no patients or staff would need to be relocated.

The Polyiso insulation provided a flat surface for the membrane to be installed on and rendered an R-value of R-3.0, making the building more energy efficient and comfortable for the patients.

Fumes! To eliminate the use of potent adhesives, the RhinoBond mechanically-fastening system was commissioned. This state-of-the-art system prevented membrane penetration and maximised wind uplift resistance.

To avoid soiling from other trades, Viking specified the use of Enviroclad APEEL, a factory applied protection film that is simply peeled off on construction completion, leaving a pristine membrane surface.

THE RESULT

The nursing home trust board members were thrilled with the fact they ended up with a low slope roof that was:

- Waterproof
- Energy-efficient through Viking WarmRoof
- Solvent-free through the use of the RhinoBond mechanical fastening system
- Pristinely-finished thanks to Enviroclad APEEL
- Backed by warranties of substance

The installation of this three-system re-roof had been achieved with minimal noise and disruption, and most importantly, without the expensive and painful process of having to remove the existing roof and relocate its precious elderly inhabitants respectively.

Viking Enviroclad Product Features

World Class Manufacturer

Carlisle Construction Materials of the USA is the largest, manufacturer of EPDM and TPO waterproofing membranes in the world. Carlisle has been supplying the international market-place with world-class materials since the 1960s.

Carlisle has a policy of aligning itself with distributors with similar values (like Viking); two of those values being a relentless emphasis on training along with the mantra of sticking with accredited 'systems' empirically tested in some of the world's most sophisticated laboratories.

Proven Record

Having been launched internationally in 1990 and introduced in NZ in 2007, Viking Enviroclad has been successfully installed, and continues to perform superbly on buildings

for significant organisations such as: Fonterra; Courier Post; Genesis Energy; Foodstuffs; Progressive Enterprises; Ryman Healthcare; Metlifecare; Ministry of Justice; Department of Corrections; Te Wananga O Aotearoa and Ballance Fertilisers to name a few.

Weldable Accessories

Viking Enviroclad is supplied as a complete system with a range of heat-weldable accessories to deal meticulously with changes in roof plane direction such as internal and external corners. It also comfortably flashes roof penetrations such as pipes; air conditioning units and substrate vents.

TPO Weldable walk way rolls with a tread-plate pattern are specified to provide further protection to the roof surface by directing the flow of foot traffic when the roof is being inspected or serviced.

Viking's Licensing Programme

The performance of any construction material rests heavily on the standard of workmanship in its installation.

At Viking, we've taken this mantra seriously by establishing New Zealand's first waterproofing licensing programme. Recognised as an industry leader, this stringent three-stage Viking licensing programme has a comprehensive curriculum and hands-on training syllabus, to ensure every installer is applying materials to specification and with attention to detail.

No applicator has access to Viking's materials or systems unless licensed. This policy has been instrumental in Viking having one of, if not, the lowest remedial rate in the industry.

Product Specification

	Enviroclad	Enviroclad colours	Enviroclad FBS	Enviroclad APEEL
Thickness	1.14mm and 1.52mm	1.52mm	2.5mm (including 1.4mm of fleece-backing)	1.52mm
Roll Width	2.44m, 3.05m, 3.66m and 4.88m (grey only)	3.05m (all colours)	3.66m	3.05m
Roll Length	30.4m	30.4m	30.4m	30.4m
Colour	Dove Grey, White (both thicknesses)	Medium Bronze, Patina Green, Rock Brown, Slate Grey, Ironsand	Grey and White	Grey
Cut-to-length	3.05m wide only	Yes	Yes	Yes
Water Potable	Yes	Yes	Yes	Yes
Product Warranty	20 Years	20 Years	20 Years	20 Years
Licensing Programme	Yes	Yes	Yes	Yes



masterspec





**Contact us here
to meet your needs**

Phone 0800 729 799

Fax 0800 729 788

info@vikingroofspect.co.nz

www.vikingroofspect.co.nz

Auckland office

80 Alexander Crescent, Otara
PO Box 14-541, Panmure
Auckland 1741, New Zealand

Wellington office

19 Pretoria St, Lower Hutt
Wellington 5010, New Zealand

Christchurch office

2 Nazareth Avenue, Middleton
PO Box 9117, Tower Junction
Christchurch 8149, New Zealand