

MS Sealant

Viking Torch-on CAP sheet 4mm thick, install as per manufacturers instructions

Viking Torch-on BASE sheet 3mm thick, install as per manufacturers instructions

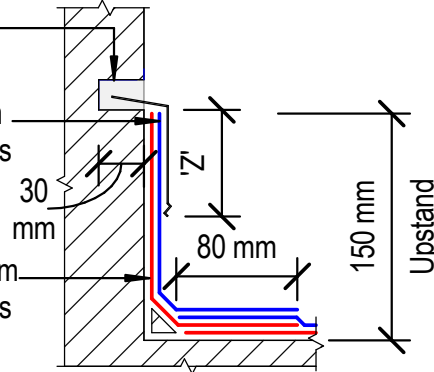

*Chase termination 'A'

Viking Torch-on CAP sheet 4mm thick, install as per manufacturers instructions

Viking Torch-on BASE sheet 3mm thick, install as per manufacturers instructions

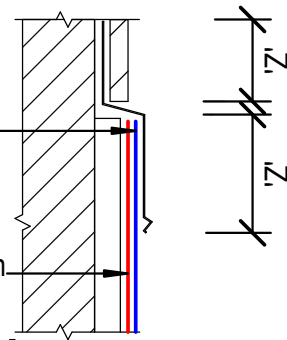

*Apron Flashing termination 'B'

Viking Termination Flashing IMT708 with STP870 water cut-off mastic sealant between membrane and wall for a compression seal

Viking Torch-on CAP sheet 4mm thick, install as per manufacturers instructions

Viking Torch-on BASE sheet 3mm thick, install as per manufacturers instructions

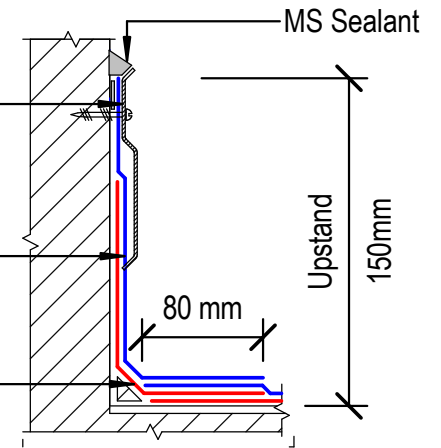

*Pressure Bar termination 'C'

Cap sheet pushed into 45° chase cut.

Seal remaining gap with bituminous compatible sealant.

Viking Torch-on CAP sheet 4mm thick, install as per manufacturers instructions

Viking Torch-on BASE sheet 3mm thick, install as per manufacturers instructions

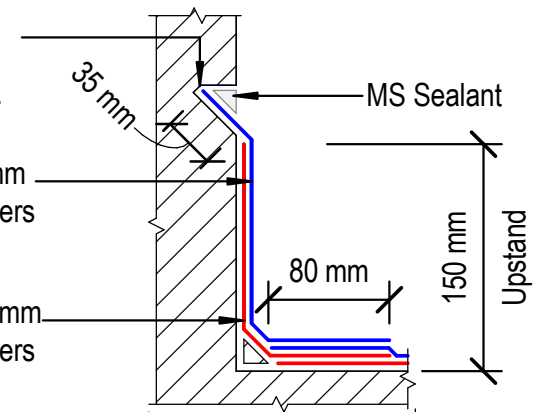

*Chase termination 'D'

NOTES:

'Z' = Variable cover according to wind zone refer table 7 E2/AS1
150mm membrane upstand height where-ever possible

NOTES:

Substrate to comply with current Viking Roofspec Masterspec specification
Substrate Checksheet available from www.vikingroofspec.co.nz

DRAWING TITLE

Viking Torch-On
Apron_Upstand terminations without cladding

NOTES:

- Viking Waterproof Membrane as notated can be Viking Gemini, Lybra or Phoenix Super.
- All fixings, cladding and structure are indicative only unless notated.

CodeMark

Cert # GM-CMNZ30092

Cert # BV-CMNZ70171

Viking Torch-On systems are CodeMarked

DRAWING

INFORMATION ONLY

Scale:	Date:	Drawn:	Viking
Not to Scale	23/11/2020		
Detail Ref:			VIK_TOR_081_APRNUTER