

Viking Enviroclad TPO waterproofing membrane 1.52 mm thick, install as per manufacturers instructions.

- STEP**
- STEP 1. Viking Enviroclad behind cavity batten fully supported by substrate plywood or timber. Finish 150mm over & beyond the parapet junction
- STEP 2. Wall Underlay behind cavity. Finish over membrane
- STEP 3. *Saddle Flashing over cavity batten, directly behind cladding, refer Fig12 E2/AS1
- STEP 4. Cladding to seal to saddle flashing
- STEP 5. Metal Cap flashing to seal to saddle flashing

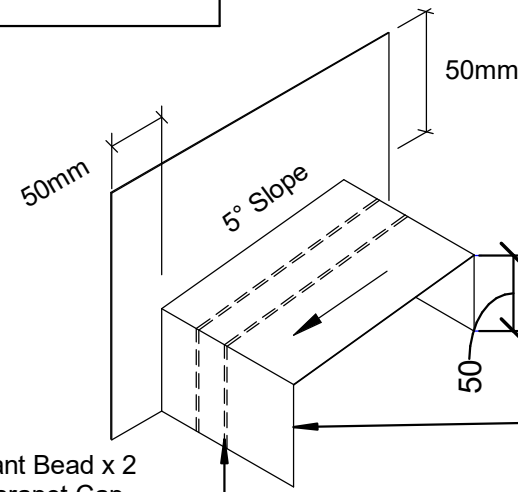

*Saddle flashing Refer E2/AS1 fig12 for detail

DRAWING TITLE

Viking WarmRoof - Enviroclad Parapet_ Timber wall ISO

NOTES:

- * Angle fillets are not required at upstands for Enviroclad
- * All fixings, cladding and structure are indicative only unless noted
- * All details to be read in conjunction with Viking Specifications

WarmRoof System is Branz Appraised - 713

DRAWING

INFORMATION ONLY

Scale:	Date:	Drawn:	Viking
Not to Scale	01/03/2022		

Detail Ref: VIK_WRE_040A_PARAWALL