

- STEPS**
- STEP 1. Viking Torch-On behind cavity batten fully supported by substrate plywood or timber. Finish 150mm over & beyond the parapet junction
- STEP 2. Wall Underlay behind cavity. Finish over membrane
- STEP 3. \*Saddle Flashing over cavity batten, directly behind cladding, refer Fig12 E2/AS1
- STEP 4. Cladding to seal to saddle flashing
- STEP 5. Metal Cap flashing to seal to saddle flashing

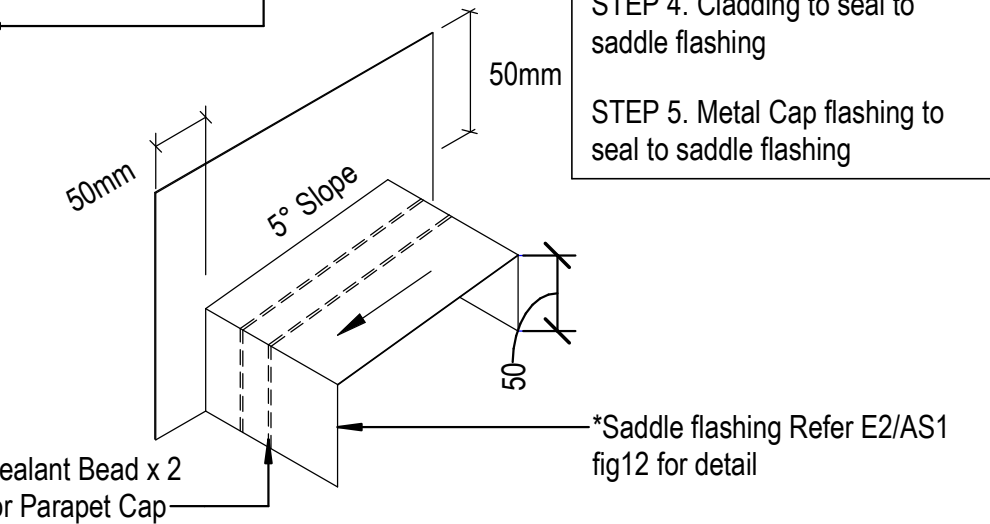

DRAWING TITLE

Viking WS2 - Torch-On  
Parapet\_ Timber wall ISO

NOTES:

\*Viking Waterproof Membrane as notated can be Viking Gemini, Lybra, Phoenix Super or Halley P.  
\*All details to be read in conjunction with Viking Specifications.

Substrate and structure are indicative only

DRAWING STATUS

INFORMATION ONLY

|                        |                     |                  |
|------------------------|---------------------|------------------|
| Scale:<br>Not to Scale | Date:<br>01/10/2022 | Drawn:<br>Viking |
|------------------------|---------------------|------------------|

Detail Ref **VIK\_WS2\_TOR\_040A\_PARAWALL**