

Viking Fixing Bar with STP870  
water cut-off mastic sealant  
between membrane and wall for a  
compression seal

MS Sealant

Structure

Viking Enviroclad TPO  
waterproofing membrane 1.52  
mm thick, install as per  
manufacturers instructions

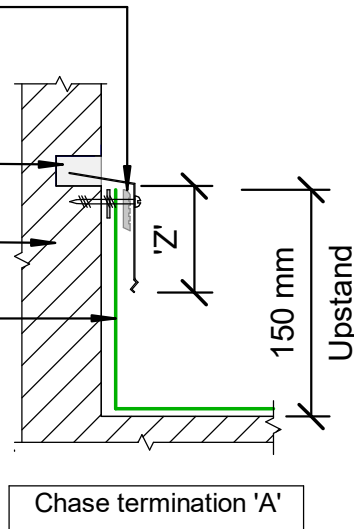

Chase termination 'A'

Viking Termination Flashing IMT708  
with STP870  
water cut-off mastic sealant  
between membrane and wall for a  
compression seal

Viking Enviroclad TPO  
waterproofing membrane 1.52  
mm thick, install as per  
manufacturers instructions

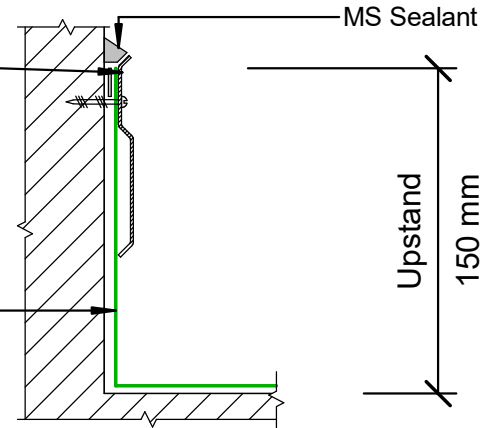

Bar termination 'B' recommended only  
where a chase detail is not possible

Viking Enviroclad TPO  
waterproofing membrane 1.52  
mm thick, install as per  
manufacturers instructions

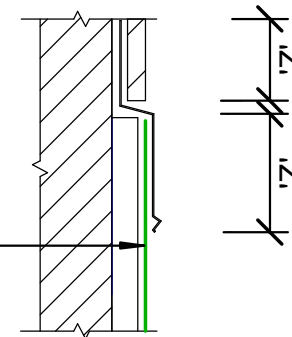

Apron Flashing  
termination 'C'

NOTES:

'Z' = Variable cover according to wind zone refer table 7 E2/AS1  
150mm membrane upstand height where-ever possible

NOTES:

Substrate to comply with current Viking Roofspec Masterspec specification  
Substrate Checksheet available from [www.vikingroofspec.co.nz](http://www.vikingroofspec.co.nz)

DRAWING TITLE

Viking Enviroclad  
Apron\_Upstand terminations without cladding

NOTES:

\* Angle fillets are not required at  
upstands for Enviroclad  
\* All fixings, cladding and structure are  
indicative only unless notated



Enviroclad  
systems are  
CodeMarked

DRAWING

INFORMATION ONLY

Scale:	Date:	Drawn:	Viking
Not to Scale	23/11/2020		

Detail Ref: **VIK\_ENV\_081\_APRNUTER**